

BALCÃO 3 - PLANTA BAIXA

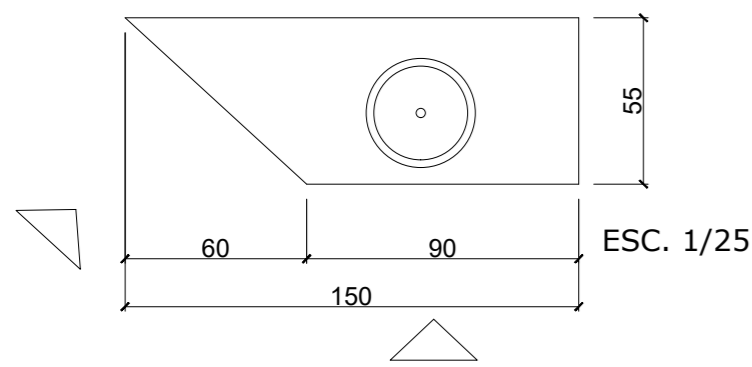

BALCÃO 3 - VISTA FRONTAL FECHADO

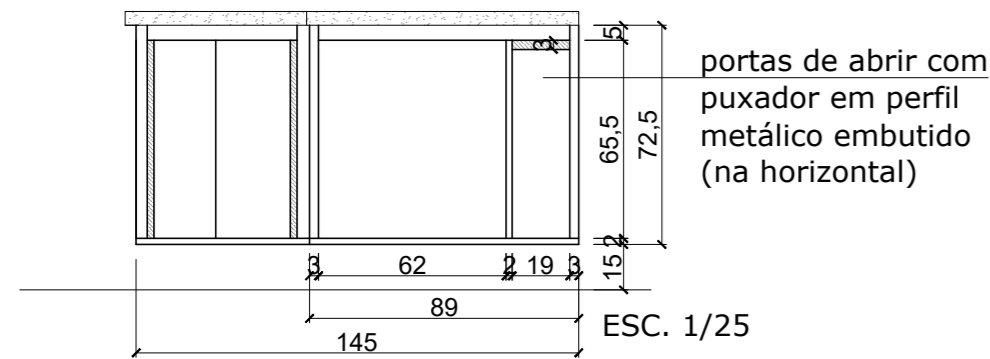

BALCÃO 3 - VISTA FRONTAL ABERTO

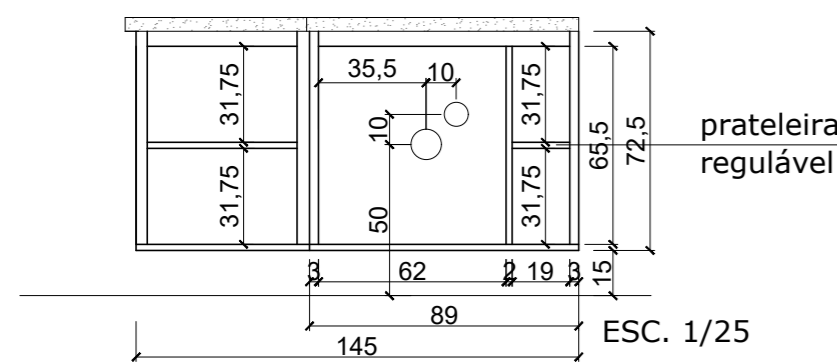

BALCÃO 3 - VISTA LATERAL FECHADO

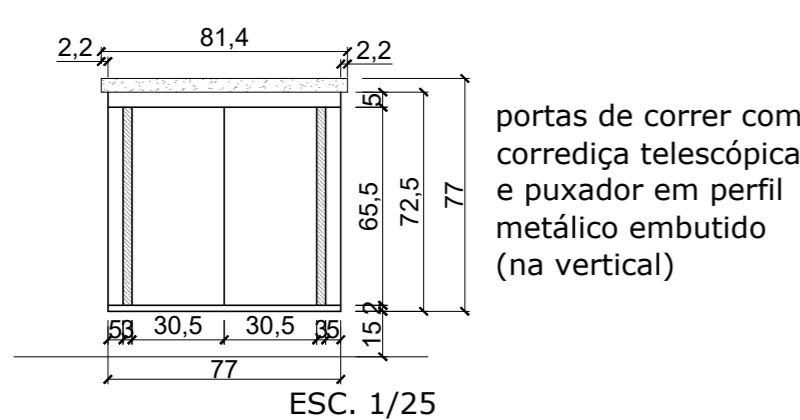

BALCÃO 3 - VISTA LATERAL ABERTO

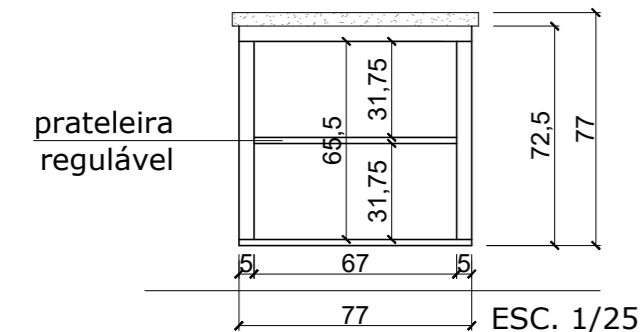

BALCÃO 4 - PLANTA BAIXA

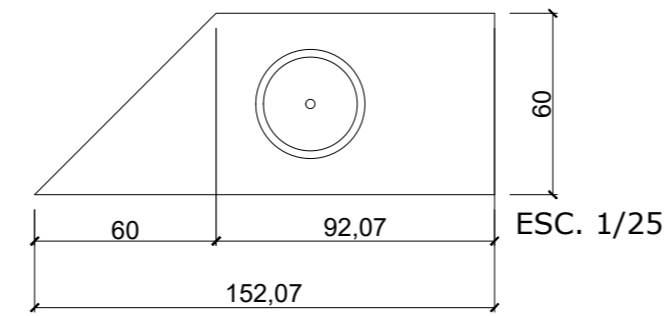

BALCÃO 4 - VISTA FRONTAL FECHADO

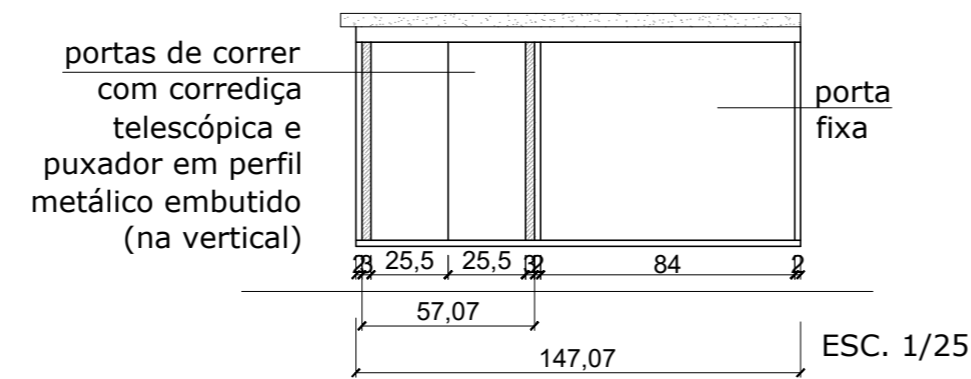

BALCÃO 4 - VISTA FRONTAL ABERTO

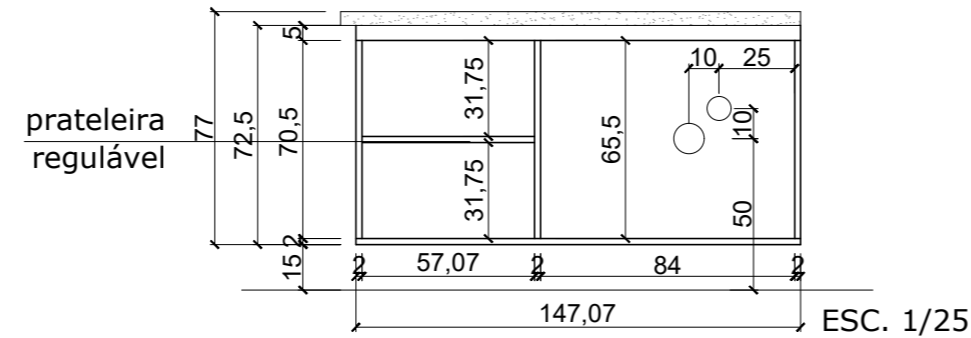

BALCÃO 4 - VISTA LATERAL

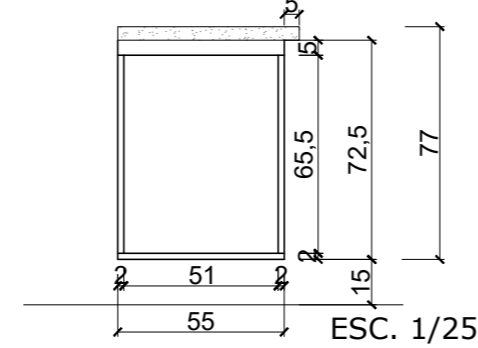

BALCÃO 5 - PLANTA BAIXA

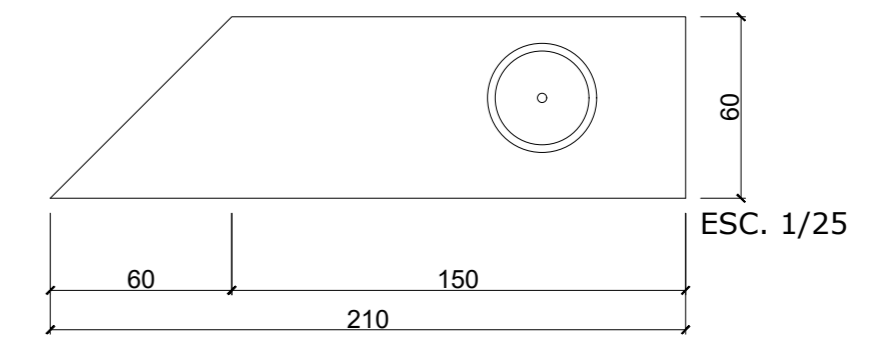

BALCÃO 5 - VISTA FRONTAL FECHADO

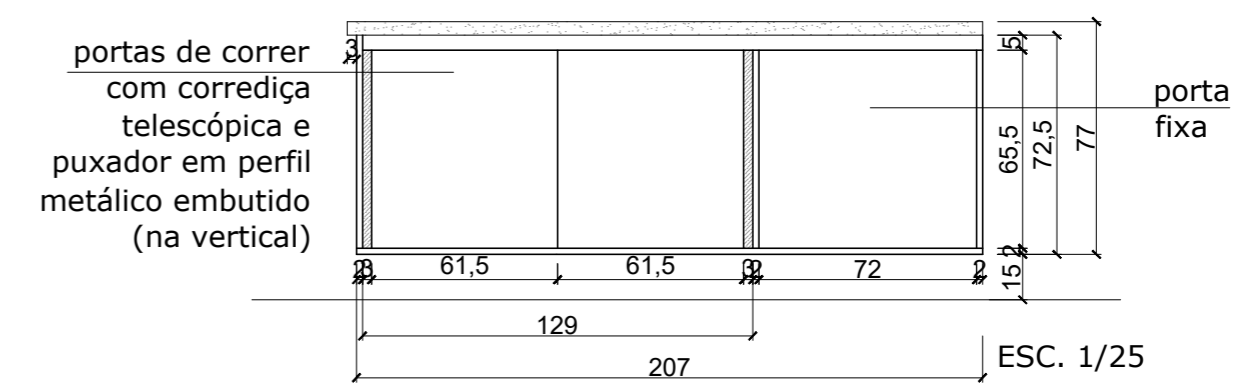

BALCÃO 5 - VISTA FRONTAL ABERTO

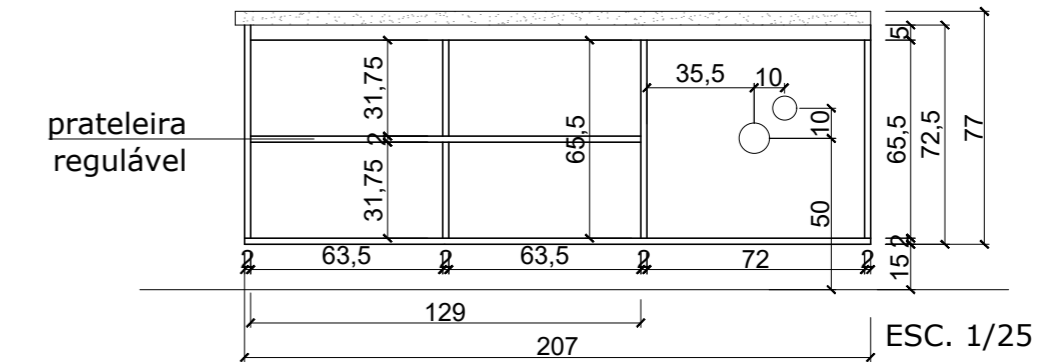

BALCÃO 5 - VISTA LATERAL

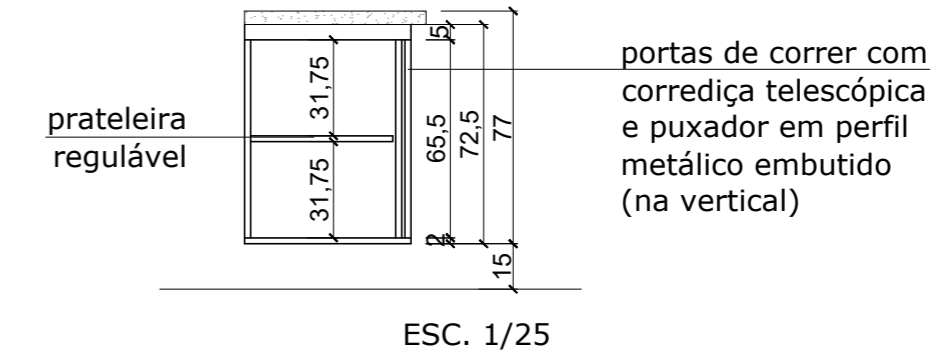

OBSERVAÇÕES/MODIFICAÇÕES:

SALA	MOBILIÁRIO	SOLICITAÇÃO DE ALTERAÇÃO

OBSERVAÇÃO: SOLICITAÇÕES DE ALTERAÇÕES NOS PROJETOS SERÃO ANALISADAS CONFORME ASPECTOS TÉCNICOS E ERGONÔMICOS. S UA CONFIRMAÇÃO SERÁ COMUNICADA POSTERIORMENTE.

PROJETOS APROVADOS PARA ENVIAR A ORÇAMENTO

SALA	MOBILIÁRIO	ASSINATURA

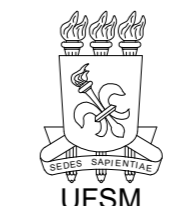
 UFESM	PRÓ-REITORIA DE INFRAESTRUTURA COORDENADORIA DE OBRAS E PLANEJAMENTO URBANO E AMBIENTAL		
	DATA: JUN/18	PRÓ REITORIA DE ASSUNTOS ESTUDANTIS - PRÉDIO 48D	
ESCALAS: Indicadas	SERVIÇO DE ATENDIMENTO EM ODONTOLOGIA		
DESENHO MARIA BARCELOS	SALAS ATENDIMENTO 1, 2 E 3	Arq. Gianine Mello	02/02